

Product Installation Guidelines

Version 1, 9 July 2024, Page 1 of 5

Ezy-Wash[®] CP Lead Safe[™] Ezy-Wash Pot Filler Attachment Type 100 J/V 305mm Reach

PRODUCT CODES:

- 181.91.31.02

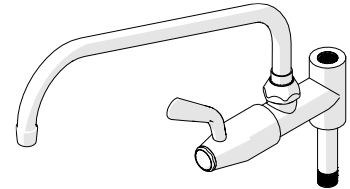

SPECIFICATIONS

- Galvin Engineering Pre-Rinse Pot Filler easily installs into a standard pre-rinse tap assembly.
- Convenient, versatile use that quickly and easily fills stock pots and kettles.
- Galvin Engineering recommends installation of pot filler attachments are conducted by a qualified plumber.
- The identification button on the handle is standard and signifies hot water only. If water other than hot is used (e.g cold) then appropriate identification buttons will need to be purchased to replace those supplied on the standard unit.
- Lead Safe[™] brass construction.*

IMPORTANT: All Ezy-Wash taps are tested in accordance with AS/NZS 3718 and leave our premises in good working order.

*Our Lead Safe[™] product range is compliant with the Lead Free Requirements of the NCC 2022 Vol. Three, Clause A5G4(2) and NSF/ANSI 372.
 **Any flow controller incorporated in the outlet to be tightened to prevent removal by hand. As Per AS3718.

WARNINGS: Special attentions to be paid on notes, photos, images, or drawings of assembly steps marked with the warning symbol.



TECHNICAL DATA

Inlet	3/8" NPT	
Outlet	Aerator	
Headwork	Jumper Valve	
Working Pressure Range (kPa)	Min	100
	Max	500
Working Temperature Range (°C)	Min	5
	Max	65
Construction	Brass	
Finish	Chrome	

NOTE: Galvin Engineering continually strives to improve their products. Specifications may change without notice. Higher temperature or pressures could result in premature failure and void the manufacturer's warranty.

TOOLS REQUIRED

- Power drill
- Spanner or adjustable crescent

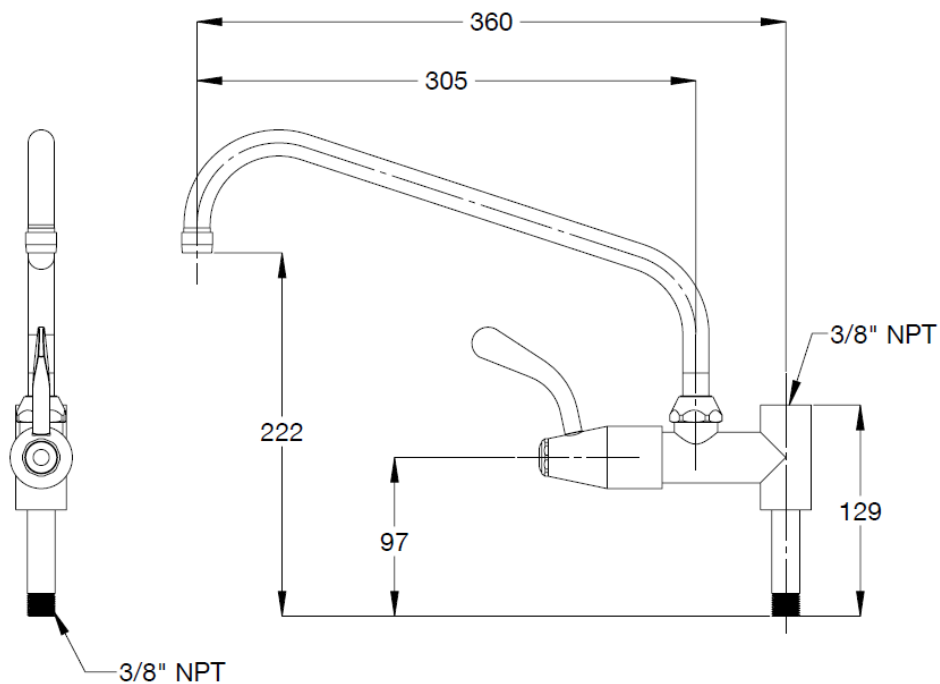
DIMENSIONS**PRE-INSTALLATION**

This installation instruction has two (2) sections:

1. New Installation
2. Retro-Fit

Select the appropriate section and follow the instructions carefully.

⚠ Note: When a pot filler attachment is installed, the overall height of the pre-rinse unit will increase by 130mm.

INSTALLATION

INSTALLATION COMPLIANCE: Galvin Engineering products must be installed in accordance with these installation instructions and in accordance with AS/NZS 3500, the PCA and your local regulatory requirements. Water and/or electrical supply conditions must also comply to the applicable national and/or state standards. Failing to comply with these provisions shall void the product warranty and may affect the performance of the product.

New Installation: (The following instructions must be read in conjunction with installation and operation instructions supplied with new pre-rinse unit).

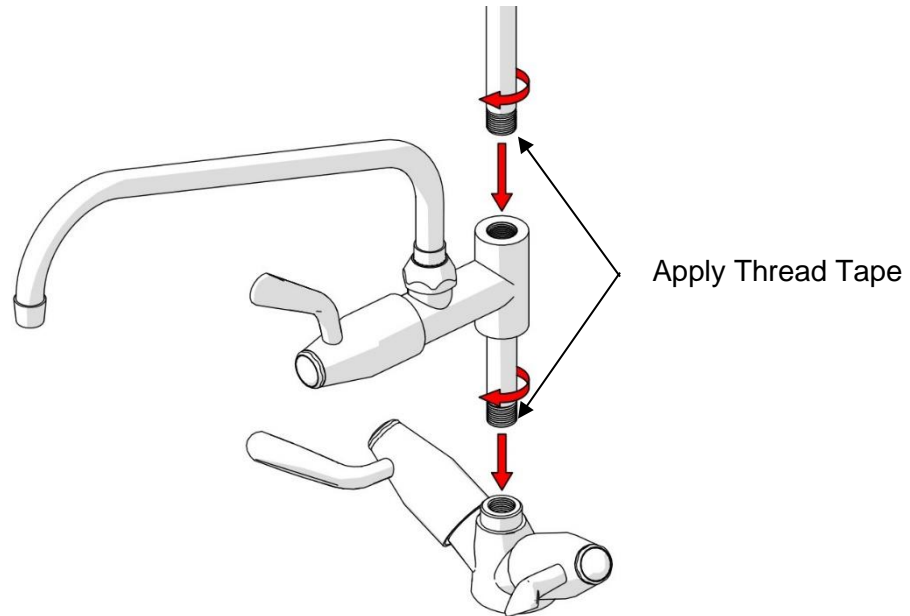

1. Fit pot filler and riser

- Fit the pot filler to the tap body.
- Apply thread tape / sealant to the bottom of the riser.
- Fit the riser to the pot filler.

Retro-Fit - Installation to standard Ezy-Wash Pre-Rinse range (existing unit will need to be isolated at the control valves)

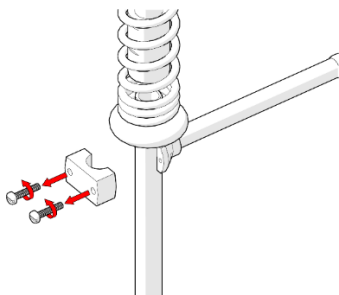

1. Loosen riser

- Unscrew the bracket holding the riser to the support rod.

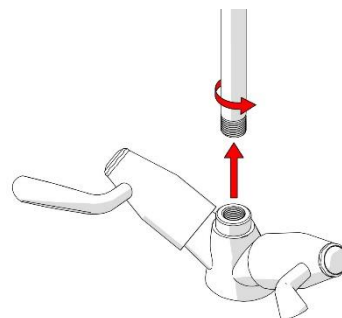

2. Disassemble pre-rinse riser

- Unscrew riser from body assembly.
- Separate top riser.

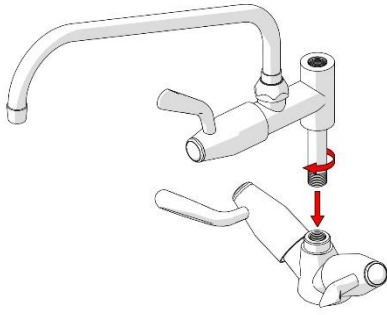

3. Fit pot filler onto body

- Fit the pot filler onto the tap body. Ensure the sealing washer is used.
- Apply thread tape / sealant to the bottom thread of the pot filler.

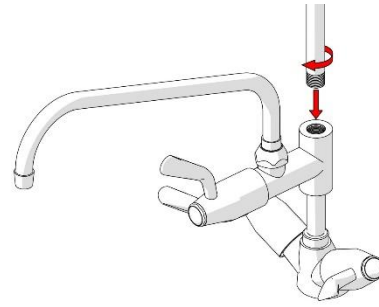

4. Fit pre-rinse riser assembly

- Fit the riser onto the pot filler. Ensure the sealing washer is used.
- Apply thread tape / sealant to the bottom thread of the riser.

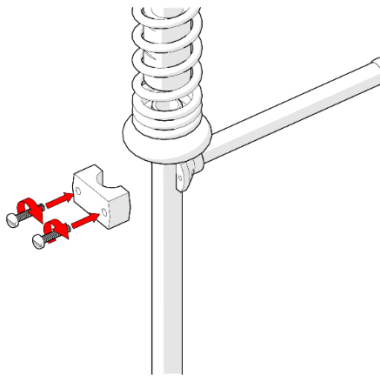

5. Secure the riser

- Secure the riser back to the support rod using the bracket.

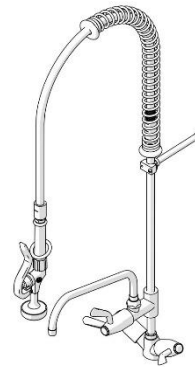

6. Test unit

- Once all fittings have been tightened securely, connect the unit to the mains water.
- Turn on water and test the unit for any leaks.

WARNINGS

⚠ For optimum performance it is recommended that the isolation or mains taps are turned off whilst the unit is not in use (overnight etc.), so that the unit is not under mains pressure when unsupervised. Flood damage may occur if a failure occurs whilst the unit is under mains pressure (warranty is void in this instance).

⚠ Galvin Engineering recommends that the handpiece is periodically serviced by a qualified plumber.

⚠ IMPORTANT:

To seal the hose this unit uses Loctite 577 which is a thread sealant approved for use with potable water (AS/NZS 4020). If hose is to be removed for maintenance purposes, reseal the joints with Loctite 577, or an equivalent sealant compliant with AS/NZS 4020. Do not use thread tape to seal the hose connections, as this may cause the hose nut to become loosened over time and leak.

WARRANTY

Galvin Engineering products are covered under our Manufacturer's Warranty. Galvin Engineering products must be installed in accordance with the installation instructions and in accordance with AS 3500 and NCC Volume Three, relevant Australian Standards and local authorities applicable to product being installed. Water and electrical supply conditions must also comply to the applicable national and/or state standards, failing to comply with these provisions may void the product warranty and affect performance of the product.

Please visit www.galvinengineering.com.au to view the full warranty, our Installation Compliance and Maintenance & Cleaning information as well as any other additional information.